

# INSTRUCTIONS FOR INTERNAL HYDRANTS



**ENG**

# TABLE OF CONTENTS

## INSTRUCTION OF ASSEMBLY FOR THE INTERNAL HYDRANT 33

SPECIFICATION OF HYDRANTS	3
LIST OF SPARE PARTS	
COMMENTS	
STORAGE INSTRUCTIONS FOR INTERNAL HYDRANTS AND METAL PRODUCTS	
ASSEMBLY OF THE INTERNAL HYDRANT 33	4
USE OF SUPPORTS AND BASES	
METHOD OF ASSEMBLY THE INTERNAL HYDRANT 33	5
ASSEMBLY OF THE INTERNAL HYDRANT 33 IN SIDE VERSION	6

## INSTRUCTION OF CONNECTING AND CHANGING CONNECTION OF INTERNAL HYDRANT 33

OPERATIONS NEEDED FOR CHANGING CONNECTION TO WATER PIPE	7
CHANGING THE HYDRANT CONNECTION TO WATER PIPE	
TYPE OF VALVE CONNECTING IN INTERNAL HYDRANT 33	8
OPERATIONS NEEDED FOR CHANGING CONNECTION SIDE	9
INSTRUCTIONS FOR ASSEMBLING THE FOUR-ELEMENT FRAME IN THE HYDRANT CABINETS	

## POSITION OF THE HOSE REEL ARM IN HYDRANT 33 AND HYDRANT 33 (VERTICAL VERSION)

CHANGING OF HOSE REEL ARM POSITION FROM RIGHT TO LEFT SIDE CONNECTION	10
CHANGING OF HOSE REEL ARM POSITION FROM LEFT TO RIGHT SIDE CONNECTION	
CHANGING OF HOSE REEL ARM POSITION FROM RIGHT TO LEFT SIDE CONNECTION IN HYDRANT 33 VERTICAL VERSION	
CHANGING OF HOSE REEL ARM POSITION FROM LEFT TO RIGHT SIDE CONNECTION IN HYDRANT 33 VERTICAL VERSION	

## INSTRUCTION OF ASSEMBLY FOR THE GLASS IN THE WINDOW WITH KEY

PATENT LOCK	12
-------------	----

## INSTRUCTION OF MAINTENANCE

REGULATIONS	13
GENERAL RECOMMENDATIONS	

## DECLARATION OF PERFORMANCE

## WARRANTY CARD

## SPECIFICATION OF HYDRANTS

The hydrant is delivered in one package, which includes:

- hydrant cabinet mounted in recess (W) or mounted on the wall (Z)
- connector (connecting hose)
- fire hose reel with semi-rigid hose  $\varnothing 33$  (30 mb or 20 mb) and hydrant nozzle type PWh 33 (fixed connection to fire hose)
- hydrant valve ZH 52 or ball valve 32 (option)
- folding collar for a recessed hydrant cabinet (W)

## LIST OF SPARE PARTS

- hydrant cabinet body, cabinet door or a complete hydrant cabinet
- retractable arm
- fire hose reel (complete with semi-rigid hose and nozzle PWh-33)
- connector (connecting hose) - **for the ZH 52 valve** or connector (connecting hose) - **for the ball valve 32**
- folding collar for a recessed hydrant cabinet (W)
- glass pane (key protection)
- Patent lock
- hydrant valve ZH 52 or ball valve 32
- supports, bases
- key

## COMMENTS

- During the installation the front of the cabinet should be protected against building materials and mechanical damage (dirt, paintings, etc.), or installed after finishing the works.
- If it is not possible to install the cabinet on a wall or in a recess (e.g. a drywall or the need to install a hydrant in the middle of a large warehouse), use supports or bases, which will be delivered with the cabinet by the manufacturer at the customer's additional order.
- Use flat wrenches when assembling all fasteners with flats or mounting hexagons.  
Apply lubricant to the threads of the aluminum fasteners before assembly.
- Checking the tightness of connections, service inspection (including the pre-delivery inspection) can only take place, when the hydrant installation is free of any contamination!

## STORAGE INSTRUCTIONS FOR INTERNAL HYDRANTS AND METAL PRODUCTS

1. Internal hydrants and metal products should be stored in warehouses or in roofed and ventilated spaces that provide protection against weather and environmental factors.
2. Storage conditions: ■ temperature from + 5 °C to + 25 °C ■ humidity from 40% to 60% ■ no longer than 1 year without use
3. The packaging should not be allowed to get wet or damp. In this case, the packaging should be replaced immediately, drying the product first.
4. Do not allow contact with aggressive substances, in particular solvents which contain esters, ketones, alcohols, aromatic compounds, glycol ethers and halogen hydrocarbons, and with acidic, alkaline and abrasive properties. **NOTE:** In case of contact with the abovementioned substances, you can attempt to repair them in accordance with the maintenance and cleaning instructions for powder coated and stainless steel cabinets available at [www.supron.pl](http://www.supron.pl)
5. Products should be stored on pallets or other flat surface. It is recommended that the minimum distance of the package from the floor is 10 cm.
6. Store, move, transfer, etc. in accordance with the direction indicated on the packaging, if it is not available - door upwards with special care not to cause damage.
7. Stack products of only one dimension up to max. 2.2 m high, with special care not to cause damage.

## ASSEMBLY OF THE INTERNAL HYDRANT 33

- Install the hydrant cabinet on the wall (Method of assembly - Fig. 1) using  $\varnothing 10$  wall plugs or in the recess (Method of assembly - Fig. 2) using wall plugs and polyurethane foam.
- Install hydrant valve ZH 52 or ball valve 32 to the water pipe (NOTE! The distance between the hydrant valve ZH52 and the wall of hydrant cabinet should be max 70 mm and 20 mm for ball valve 32).
- Check the tightness of the valve connection to the water system after installing the valve. (NOTE! Installation must be clean)
- Install a fire hose reel with a semi-rigid hose
- Connect hydrant valve with fire hose reel (water axis) using a connector (connecting hose) in that order:  
**For hydrant valve 32:** threaded (fixed) connector with a water axis, then a set of connectors with a hydrant valve,  
**For hydrant valve ZH 52:** threaded (fixed) connector with a water axis, then a connector with a rotary adapter and a hydrant valve.
- Set the hydrant nozzle to STOP position (closed)

## USE OF SUPPORTS AND BASES

The height of supports and bases is selected so that the hydrant valve is mounted at 1350 mm from the floor.

### Supports and bases for internal hydrants 33

Hydrant type	Height of support or base	No of supports or base
PN-EN 671-1(Z-33)	700 mm	2 pc.
PN-EN 671-1(Z-33G)	700 mm	2 pc.
PN-EN 671-1(Z-33G) vertical version	550 mm	2 pc.
PN-EN 671-1(W-33)	700 mm	2 pc.
PN-EN 671-1(W-33G)	700 mm	2 pc.
PN-EN 671-1(W-33G) vertical version	550 mm	2 pc.

5 holes – diameter 10mm

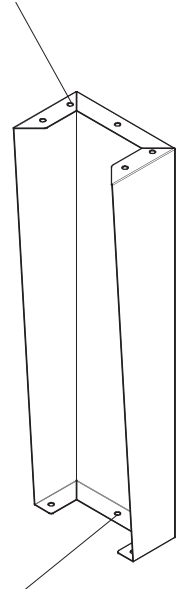

3 holes – diameter 10mm

### Supports and bases for internal hydrants 33 - side version

Hydrant type	Height of support or base	No of supports or base
PN-EN 671-1(Z-33) side version	700 mm	2 pc.
PN-EN 671-1(Z-33G) side version	450 mm	2 pc.
PN-EN 671-1(W-33) side version	700 mm	2 pc.
PN-EN 671-1(W-33G) side version	450 mm	2 pc.

## METHOD OF ASSEMBLY THE INTERNAL HYDRANT 33

Fig. 1 Internal hydrant mounted on the wall

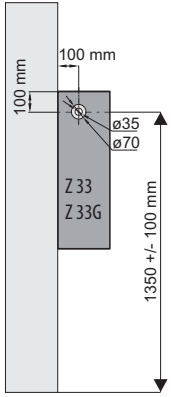

on the wall

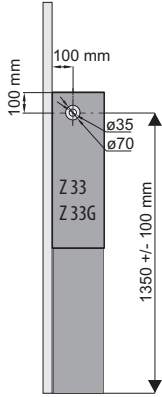

by a wall of drywall  
and as a free-standing  
with the use of bases

Fig. 2 Internal hydrant mounted in recess

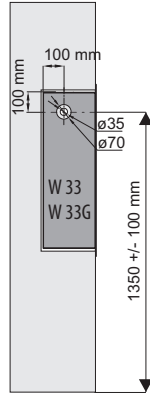

in recess

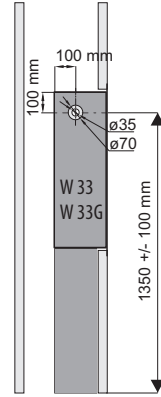

in a wall of drywall  
with supports

## METHOD OF ASSEMBLY THE INTERNAL HYDRANT 33 - SIDE VERSION

Fig. 1 Internal hydrant mounted on the wall

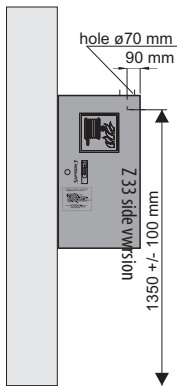

on the wall

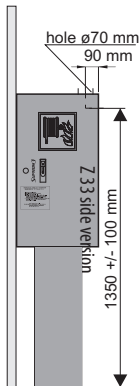

by a wall of drywall  
and as a free-standing  
with the use of bases

Fig. 2 Internal hydrant mounted in recess

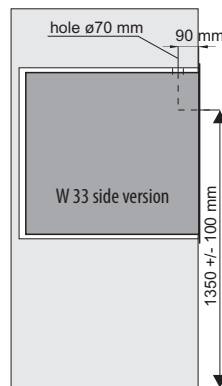

in recess

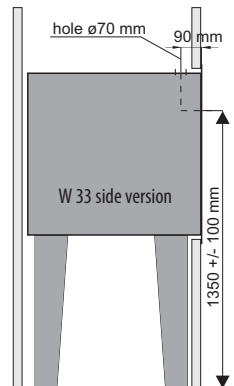

in a wall of drywall  
with supports

## ASSEMBLY OF THE INTERNAL HYDRANT 33 IN SIDE VERSION

- Install the hydrant cabinet on the wall (Method of assembly - Fig. 1) using  $\varnothing 10$  wall plugs or in the recess (Method of assembly - Fig. 2) using wall plugs and polyurethane foam. Pay attention to the vertical position of the cabinet.
- Install hydrant valve ZH 52 or ball valve 32 to the water pipe.
- Check the tightness of the valve connection to the water system after installing the valve. (NOTE! Installation must be clean)

### Assembly the fire hose reel in cabinet:

- Take out the hose reel in carton from cabinet
- Unscrew the locking screw in the slider (4)
- Extend the arm slider (4) and put the fire hose reel (2) into the sleeve
- Screw the connecting hose with a seal (3) into the sleeve fire hose reel
- Insert arm slider (make sure that the connecting hose isn't kink) and secure with the screw
- Set the hydrant nozzle to STOP position (closed)
- Wind the hose on the fire hose reel until the nozzle is seated in the guide (6)
- Connect the other end of the connecting hose to the valve (5)

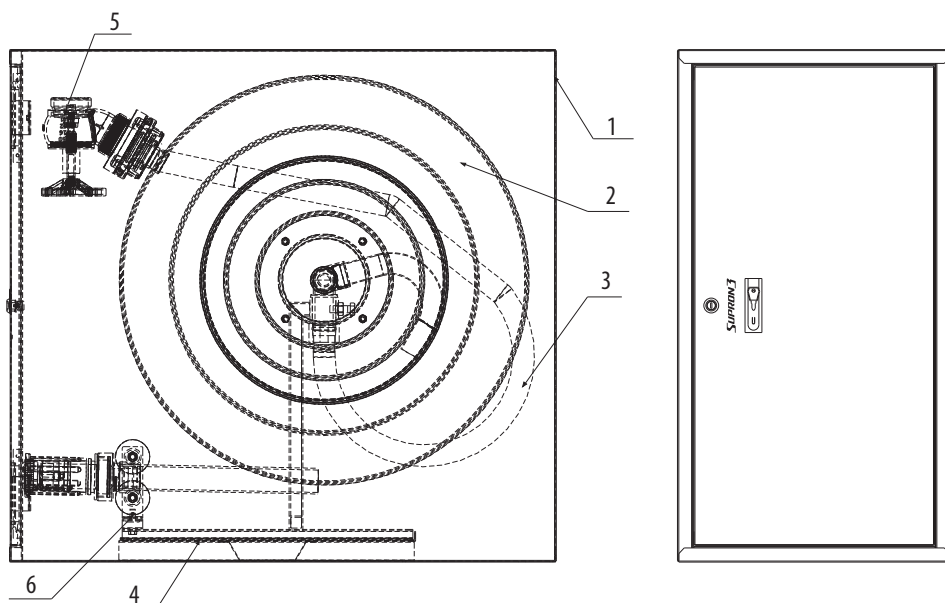

1 - Hydrant cabinet mounted on the wall

2 - Fire hose reel

3 - Connection hose

4 - Arm slider

5 - Hydrant valve

6 - Hydrant nozzle

# MANUAL HOW TO CHANGE CONNECTION SIDE OF INTERNAL HYDRANT 33

## OPERATIONS NEEDED FOR CHANGING CONNECTION TO WATER PIPE

SUPRON 3 manufactures internal hydrant with left door (hinge on left side) and left water pipe connection or according to customer's wish. Installer can change left connection and left door to right connection and right door (before assembling cabinet). Hydrant cabinet has universal connection thanks to blanked connecting holes – placed at side, back and top of cabinet. Stickers for marking internal hydrant and documentation are placed in zip-plastic bag inside cabinet (on door).

### INTERNAL HYDRANT 33 - CHANGING FROM LEFT TO RIGHT SIDE CONNECTION

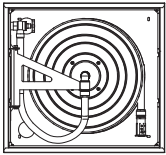

Connection at left side

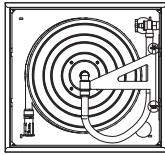

Connection at right side

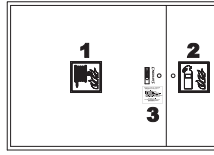

Correct hydrant's marking

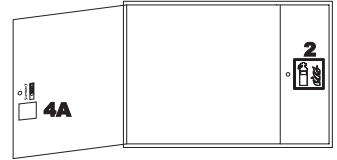

Hydrant's marking inside of the door

### INTERNAL HYDRANT 33 - CHANGING FROM RIGHT TO LEFT SIDE CONNECTION

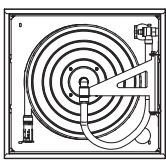

Connection at right side

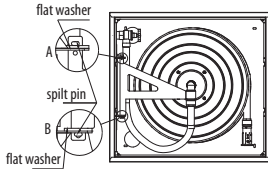

Connection at left side

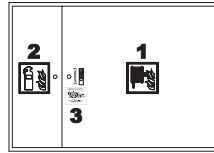

Correct hydrant's marking

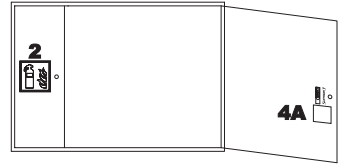

Hydrant's marking inside of the door

### INTERNAL HYDRANT 33 (VERTICAL VERSION) - CHANGING FROM LEFT TO RIGHT SIDE CONNECTION

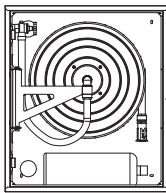

Connection at left side

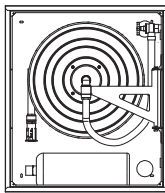

Connection at right side



Correct hydrant's marking

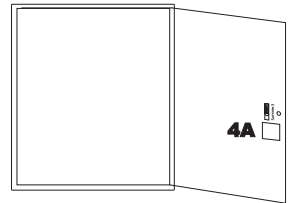

Hydrant's marking inside of the door

### INTERNAL HYDRANT 33 (VERTICAL VERSION) - CHANGING FROM RIGHT TO LEFT SIDE CONNECTION

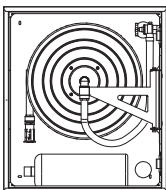

Connection at right side

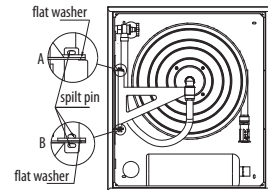

Connection at left side



Correct hydrant's marking

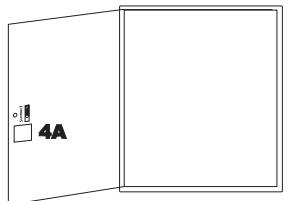

Hydrant's marking inside of the door

## CONNECTING VERSION NO 1 (HYDRANT'S BALL VALVE 32)

The assembly of the ball valve 32 to the supply pipe should be made after unscrewing the pipe joint with the couplings set. To this set screw connecting hose. Set the angular position of the valve outlet connection in this way that connection hose keeps its regular shape without kinks.

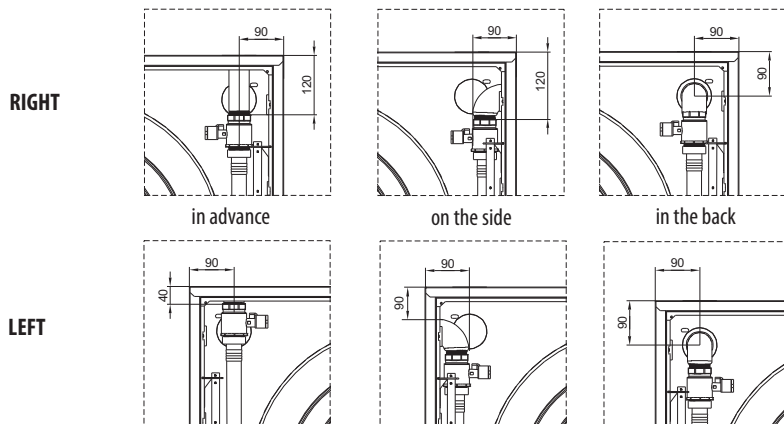

**NOTE!** The distance of the ball valve 32 from the wall of the cabinet should not exceed 20 mm.

## CONNECTING VERSION NO 2 (HYDRANT'S VALVE ZH-52)

Short connecting hose can't be kinked and convolute. Length of connecting hose is always 1m.

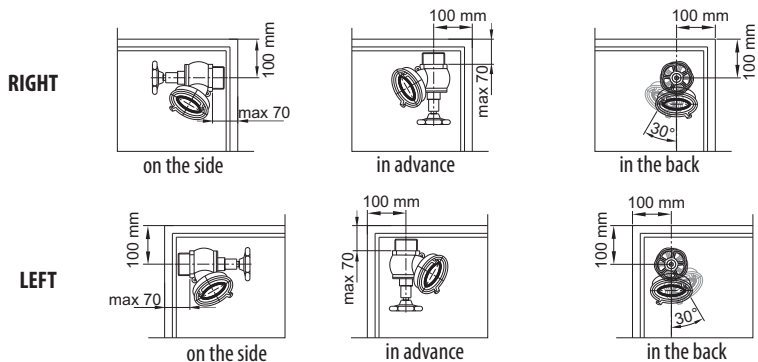

**NOTE!** The distance between the valve ZH-52 and the wall of hydrant cabinet should be max 70 mm .



# INSTRUCTION OF CONNECTING AND CHANGING CONNECTION OF INTERNAL HYDRANT 33

## OPERATIONS NEEDED FOR CHANGING CONNECTION SIDE

You can change connection side (without changing hydraulic properties) taking following operations:

- Take out the hose reel in carton from cabinet
- Take out the hose reel arm
- Rotate the cabinet by 180°
- Install the hydrant cabinet on the wall or in the recess
- Fix the position of the arm in a mirror image to the original by moving sleeves and cotters
- Assembly the hydrant valve to the supply pipe as described above
- Assembly the hose reel in the arm
- In case of the cabinet with Patent lock change to position of the key – according to the further manual
- Put the stickers on the hydrant cabinet:

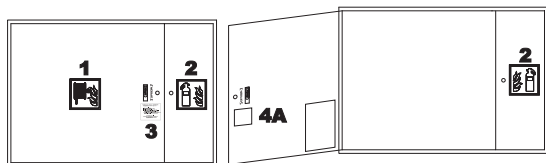

Sticker no. 1 - "Hydrant sign"

Sticker no. 2 - "Extinguisher sign" (for a hydrant with a fire extinguisher in a combi version)

Sticker No. 3 – Hydrant manual

Sticker no. 4A – Information about hydrant's type (Fig. 4 - inside the door)

**NOTE!** The hydrant's markings presented in the instructions are in accordance with EN 671-1: 2012. Failure to follow the manufacturer's instructions may results in loss of warranty.

## INSTRUCTIONS FOR ASSEMBLING THE FOUR-ELEMENT FRAME IN THE HYDRANT CABINETS

The steps to install the frames are as follow:

1. Insert one vertical frame profile (2) between the door (4) and the cabinet body (5) from the door hinge side.
2. Open the door (4) as widely as possible and lean back the hinge (6).
3. Attach the profile to the cabinet body (5) using two metal sheet screws (3)
4. Put the second vertical frame profile (2) to the cabinet body (5).
5. Attach the second vertical frame profile (2) to the body (5) using two metal sheet screws (3)
6. Attach the horizontal frame profiles (1) in the same way as above.

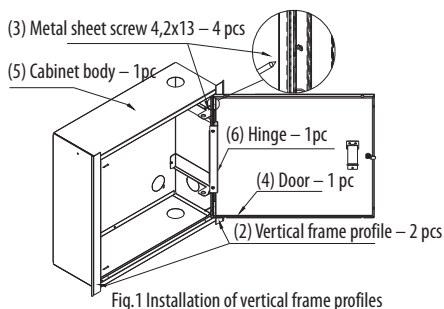

Fig.1 Installation of vertical frame profiles

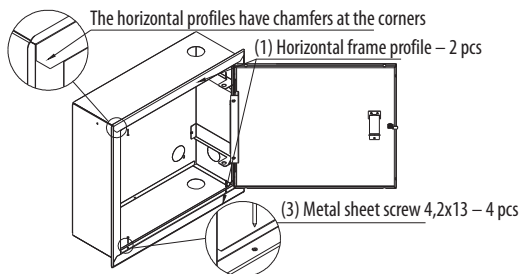

Fig.2 Installation of horizontal frame profiles

If additional construction works are required around the recess, please remove the frames to avoid damaging of the coating.

## CHANGING OF HOSE REEL ARM POSITION FROM LEFT TO RIGHT SIDE CONNECTION

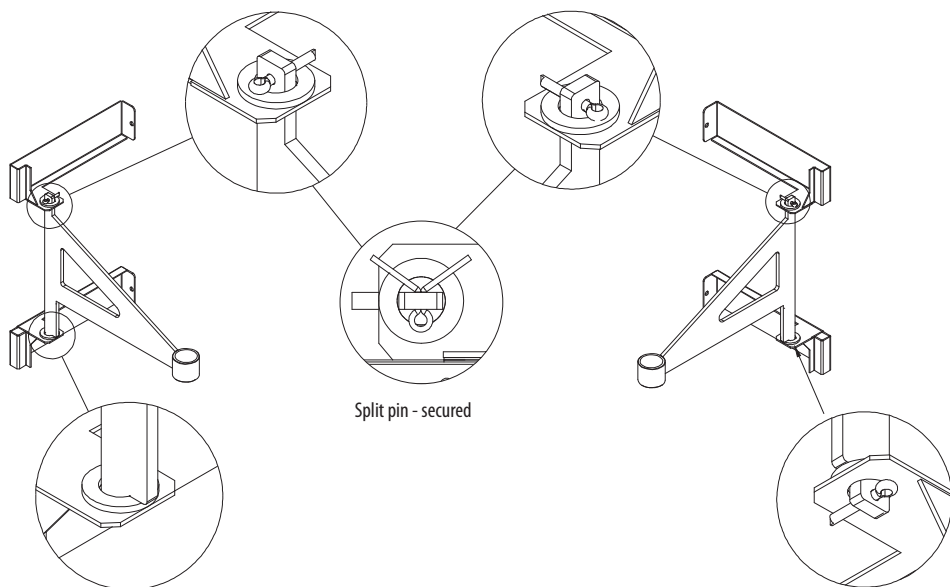

Fig.1 Position for connection on the left side

Fig.3 Position for connection on the right side

## CHANGING OF HOSE REEL ARM POSITION FROM RIGHT TO LEFT SIDE CONNECTION

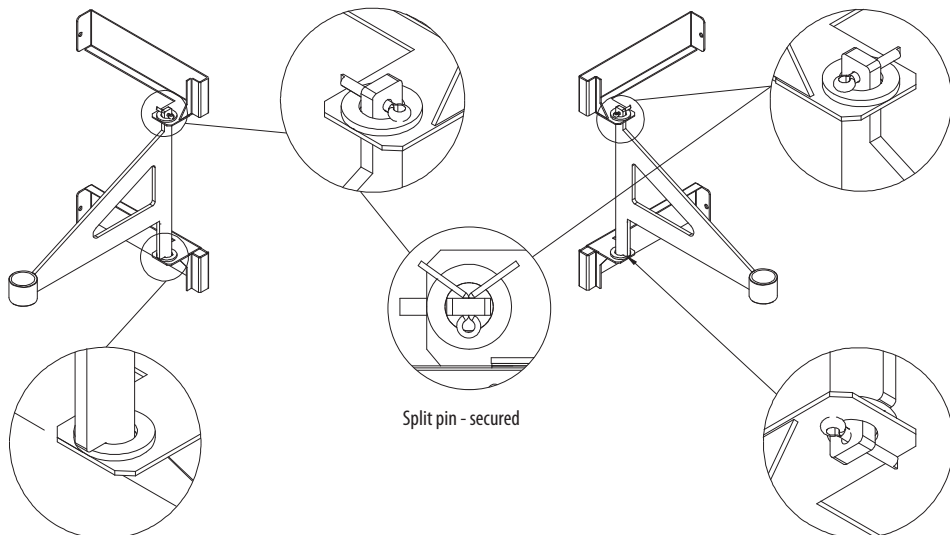

Fig.1 Position for connection on the right side

Fig.3 Position for connection on the left side

# POSITION OF THE HOSE REEL ARM IN HYDRANT 33 (VERTICAL VERSION)

## CHANGING OF HOSE REEL ARM POSITION FROM LEFT TO RIGHT SIDE CONNECTION

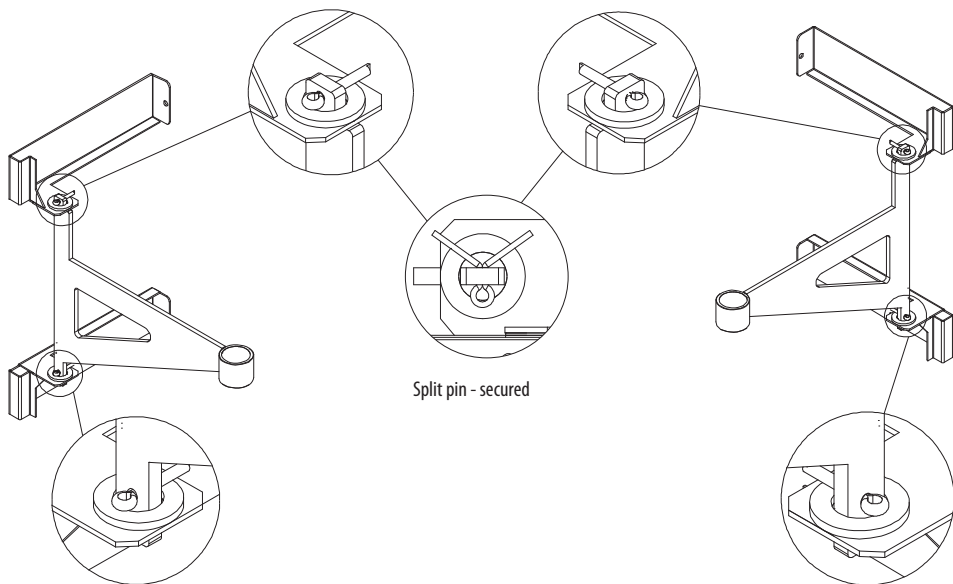

Fig.1 Position for connection on the left side

Fig.3 Position for connection on the right side

## CHANGING OF HOSE REEL ARM POSITION FROM RIGHT TO LEFT SIDE CONNECTION

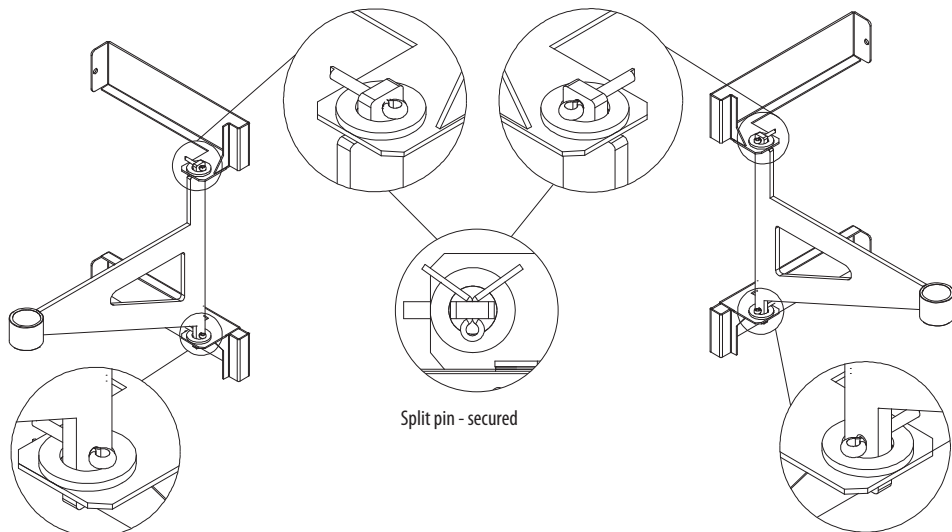
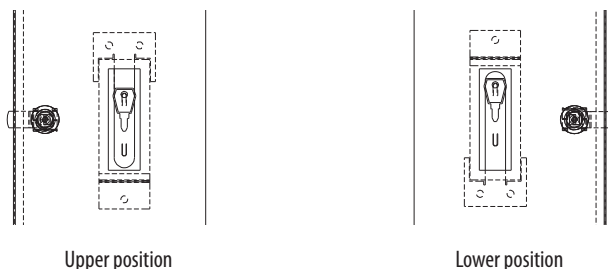

Fig.1 Position for connection on the right side

Fig.3 Position for connection on the left side

## PATENT LOCK

The cabinets with patent lock have a safety glass with a key for emergency opening.  
The key is hung only in one variant in a way that makes it easier to swing out.



If you need to change the side of hydrant connection, the direction of opening cabinet door, replace the broken glass or after finding the wrong key suspension (on the lower catch):

- Open the door
- Pull out the plastic glass lock
- Pull out the glass; scraps of glass after breaking
- Remove the key from the lower catch (applies to incorrect suspension)
- Hang the key on the upper catch and bend the catch
- Bend spring plate in the direction - outside the cabinet, giving it elastic properties - Fig. 1
- Slowly bend metal plate in the direction inside of cabinet through the window
- Slide the glass into the guide so that the key is behind it - Fig. 2
- Slide the lock into the guide (the insertion force should be significant to prevent the glass falling out) - Fig. 3

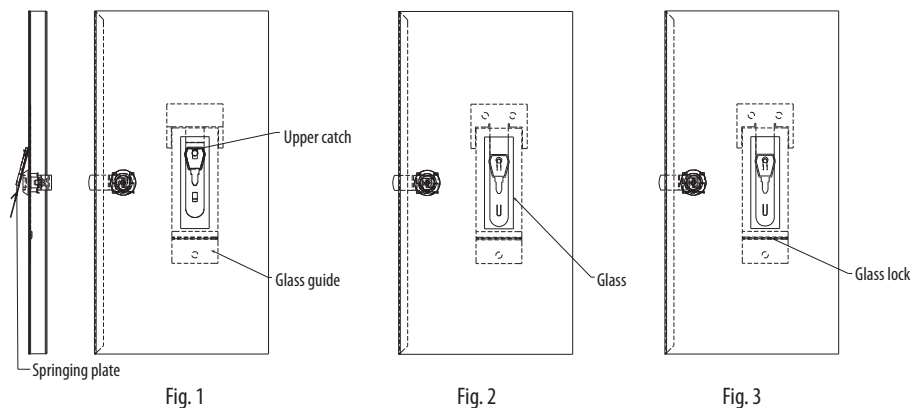

## GENERAL RECOMMENDATIONS

**The manufacturer recommends technical inspections and maintenance at least once a year and after each use of a fire hydrant.**

**Inspections and maintenance should comply with the current PN-EN 671-3 standard:**

1. The regular periodic inspection should be carried out by a responsible person, at intervals depending on the environmental conditions, to make sure that each hydrant:

- is located in the designed place
- it isn't covered, is visible and has legible markings and instructions
- no visible damage

**The responsible person should immediately take action to remove any irregularities noted.**

2. Inspections and maintenance carried out once a year must be carried out by a authorized person as follows:

Unwind fire hydrant hose completely, pressurize hydrant and check that:

- device is not blocked, undamaged, and components are not corroded or leaking
- instructions are clean and legible
- location is clearly marked
- wall mounts are suitable for their purpose and securely mounted
- water outflow is even and sufficient (it is advisable to use a flow meter and pressure gauge)
- pressure gauge (if used) works correctly and within its measuring range
- the entire length of fire hose shows no signs of damage, deformation, worn or cracks. If fire hose is damaged, it should be replaced with a new one or pressure tested to the maximum working pressure.
- hose clamps or taping are of the correct type and properly clamped
- fire hose reel rotates slightly in both directions
- in the case of a swing-out fire hose reel, whether it rotates easily and tilts 180 °
- in the case of manual fire hose reel the shut-off valve is of the correct type and works easily and correctly
- in the case of automatic fire hose reels, that the operation of automatic valve is correct and the operation of additional one the service shut-off valve is correct
- the condition of water supply pipes is good. Particular attention should be paid to whether flexible sections show signs of worn or damage
- if the fire hydrant is equipped with a cabinet, is there no signs of damage and whether cabinet door opens easily
- the nozzle is the right type and easy to use
- hose guides work correctly. Make sure that they are properly and securely attached
- leave the internal hydrant ready for immediate use. If major repairs are required, fire hydrant should be marked 'DAMAGED' and a authorized person should notify the user / owner.

Periodic inspection and maintenance of hoses:

- every 5 years hoses should be pressure tested for the maximum operating pressure of the installation, in accordance with the standards PN-EN 671-1, PN-EN 671-2.

## GENERAL RECOMMENDATIONS

### Documenting inspections and maintenance:

After the review and the necessary measurements, the internal hydrants should be marked "CHECKED" by authorized persons. Responsible persons should keep permanent records of all inspections, controls and tests. Such a record should contain:

- date (month and year) of the review and test
- list and date of spare parts installed
- additional tests to be performed, if required
- date (month and year) of the next review and tests
- a list of all internal hydrants

### Maintenance and inspection labels:

Maintenance and inspection data should be written on a label that must not cover any manufacturer's markings. The following information should be appear on the label:

- the word "CHECKED"
- name and address of the hydrant supplier
- a sign uniquely identifying the person performing the inspection or the surname and first name of the maintainer
- date (month and year) when the maintenance was carried out